

INTERNATIONAL STANDARD

GROUP SAFETY PUBLICATION

**Tests for electric cables under fire conditions – Circuit integrity –
Part 3: Test method for fire with shock at a temperature of at least 830 °C for
cables of rated voltage up to and including 0,6/1,0 kV tested in a metal enclosure**





THIS PUBLICATION IS COPYRIGHT PROTECTED
Copyright © 2018 IEC, Geneva, Switzerland

All rights reserved. Unless otherwise specified, no part of this publication may be reproduced or utilized in any form or by any means, electronic or mechanical, including photocopying and microfilm, without permission in writing from either IEC or IEC's member National Committee in the country of the requester. If you have any questions about IEC copyright or have an enquiry about obtaining additional rights to this publication, please contact the address below or your local IEC member National Committee for further information.

IEC Central Office
3, rue de Varembe
CH-1211 Geneva 20
Switzerland

Tel.: +41 22 919 02 11
info@iec.ch
www.iec.ch

About the IEC

The International Electrotechnical Commission (IEC) is the leading global organization that prepares and publishes International Standards for all electrical, electronic and related technologies.

About IEC publications

The technical content of IEC publications is kept under constant review by the IEC. Please make sure that you have the latest edition, a corrigenda or an amendment might have been published.

IEC Catalogue - webstore.iec.ch/catalogue

The stand-alone application for consulting the entire bibliographical information on IEC International Standards, Technical Specifications, Technical Reports and other documents. Available for PC, Mac OS, Android Tablets and iPad.

IEC publications search - webstore.iec.ch/advsearchform

The advanced search enables to find IEC publications by a variety of criteria (reference number, text, technical committee,...). It also gives information on projects, replaced and withdrawn publications.

IEC Just Published - webstore.iec.ch/justpublished

Stay up to date on all new IEC publications. Just Published details all new publications released. Available online and also once a month by email.

Electropedia - www.electropedia.org

The world's leading online dictionary of electronic and electrical terms containing 21 000 terms and definitions in English and French, with equivalent terms in 16 additional languages. Also known as the International Electrotechnical Vocabulary (IEV) online.

IEC Glossary - std.iec.ch/glossary

67 000 electrotechnical terminology entries in English and French extracted from the Terms and Definitions clause of IEC publications issued since 2002. Some entries have been collected from earlier publications of IEC TC 37, 77, 86 and CISPR.

IEC Customer Service Centre - webstore.iec.ch/csc

If you wish to give us your feedback on this publication or need further assistance, please contact the Customer Service Centre: sales@iec.ch.



IEC 60331-3

Edition 2.0 2018-03

INTERNATIONAL STANDARD

GROUP SAFETY PUBLICATION

**Tests for electric cables under fire conditions – Circuit integrity –
Part 3: Test method for fire with shock at a temperature of at least 830 °C for
cables of rated voltage up to and including 0,6/1,0 kV tested in a metal enclosure**

INTERNATIONAL
ELECTROTECHNICAL
COMMISSION

ICS 13.220.40; 29.020; 29.060.20

ISBN 978-2-8322-5492-9

Warning! Make sure that you obtained this publication from an authorized distributor.

CONTENTS

FOREWORD.....	4
INTRODUCTION.....	6
1 Scope.....	7
2 Normative references	7
3 Terms and definitions	8
4 Test environment.....	8
5 Test apparatus	8
5.1 Test equipment.....	8
5.2 Metal enclosure	9
5.2.1 Material and dimensions.....	9
5.2.2 Metal enclosure selection	9
5.3 Test ladder and mounting	9
5.4 Source of heat	15
5.4.1 Burner	15
5.4.2 Flow meters and flow rates.....	16
5.4.3 Verification	17
5.5 Shock-producing device.....	17
5.6 Positioning of source of heat.....	18
5.7 Continuity checking arrangements for electric power and control cables with rated voltage up to and including 600 V/1 000 V	18
5.8 Fuses.....	18
6 Test specimen (electric power and control cables with rated voltage up to and including 600 V/1 000 V).....	18
6.1 Test specimen preparation.....	18
6.2 Test specimen mounting	19
7 Test procedure (electric power and control cables with rated voltage up to and including 600 V/1 000 V).....	19
7.1 Test equipment and arrangement.....	19
7.2 Electrical connections	19
7.3 Flame and shock application.....	21
7.4 Electrification	21
8 Performance requirements (electric power and control cables with rated voltage up to and including 600 V/1 000 V)	22
8.1 Flame application time	22
8.2 Acceptance criteria	22
9 Retest procedure	22
10 Test report (electric power and control cables with rated voltage up to and including 600 V/1 000 V).....	22
Annex A (normative) Verification procedure for the source of heat	23
A.1 Measuring equipment.....	23
A.2 Procedure	23
A.3 Evaluation.....	24
A.4 Further verification.....	24
A.5 Verification report	24
Annex B (informative) Guidance on the choice of recommended test apparatus (burner and venturi)	25

Bibliography..... 26

Figure 1 – Schematic diagram of test configuration..... 11

Figure 2 – Recommended method of mounting the metal enclosure to the test ladder..... 12

Figure 3 – Plan view of fire test equipment 13

Figure 4 – End elevation of fire test equipment (not to scale) 14

Figure 5 – Typical rubber bush for supporting the test ladder 15

Figure 6 – Burner face 16

Figure 7 – Schematic diagram of an example of a burner control system 17

Figure 8 – Basic circuit diagram..... 21

Figure A.1 – Temperature measuring arrangement 23

Table 1 – Enclosure dimensions 9

Table 2 – Multicore sheathed cable..... 19

Table 3 – Single core unsheathed or sheathed cable 19

INTERNATIONAL ELECTROTECHNICAL COMMISSION

**TESTS FOR ELECTRIC CABLES UNDER FIRE CONDITIONS –
CIRCUIT INTEGRITY –****Part 3: Test method for fire with shock at a temperature of at least 830 °C
for cables of rated voltage up to and including 0,6/1,0 kV tested
in a metal enclosure**

FOREWORD

- 1) The International Electrotechnical Commission (IEC) is a worldwide organization for standardization comprising all national electrotechnical committees (IEC National Committees). The object of IEC is to promote international co-operation on all questions concerning standardization in the electrical and electronic fields. To this end and in addition to other activities, IEC publishes International Standards, Technical Specifications, Technical Reports, Publicly Available Specifications (PAS) and Guides (hereafter referred to as "IEC Publication(s)"). Their preparation is entrusted to technical committees; any IEC National Committee interested in the subject dealt with may participate in this preparatory work. International, governmental and non-governmental organizations liaising with the IEC also participate in this preparation. IEC collaborates closely with the International Organization for Standardization (ISO) in accordance with conditions determined by agreement between the two organizations.
- 2) The formal decisions or agreements of IEC on technical matters express, as nearly as possible, an international consensus of opinion on the relevant subjects since each technical committee has representation from all interested IEC National Committees.
- 3) IEC Publications have the form of recommendations for international use and are accepted by IEC National Committees in that sense. While all reasonable efforts are made to ensure that the technical content of IEC Publications is accurate, IEC cannot be held responsible for the way in which they are used or for any misinterpretation by any end user.
- 4) In order to promote international uniformity, IEC National Committees undertake to apply IEC Publications transparently to the maximum extent possible in their national and regional publications. Any divergence between any IEC Publication and the corresponding national or regional publication shall be clearly indicated in the latter.
- 5) IEC itself does not provide any attestation of conformity. Independent certification bodies provide conformity assessment services and, in some areas, access to IEC marks of conformity. IEC is not responsible for any services carried out by independent certification bodies.
- 6) All users should ensure that they have the latest edition of this publication.
- 7) No liability shall attach to IEC or its directors, employees, servants or agents including individual experts and members of its technical committees and IEC National Committees for any personal injury, property damage or other damage of any nature whatsoever, whether direct or indirect, or for costs (including legal fees) and expenses arising out of the publication, use of, or reliance upon, this IEC Publication or any other IEC Publications.
- 8) Attention is drawn to the Normative references cited in this publication. Use of the referenced publications is indispensable for the correct application of this publication.
- 9) Attention is drawn to the possibility that some of the elements of this IEC Publication may be the subject of patent rights. IEC shall not be held responsible for identifying any or all such patent rights.

International Standard IEC 60331-3 has been prepared by IEC technical committee 20: Electric cables.

This second edition cancels and replaces the first edition published in 2009. It constitutes a technical revision.

The significant technical changes with respect to the previous edition are as follows:

- extension of the scope to include metallic data and telecom cables and optical fibre cables, although details for the specific point of failure, continuity checking arrangement, test sample, test procedure and test report relevant to metallic data and telecom cables and optical fibre cables are not given by IEC 60331-3;
- improved description of the test environment;

- mandatory use of mass flow meter/controllers as the means of controlling accurately the input flow rates of fuel and air to the burner;
- improved description of the information to be included in the test report.

The text of this International Standard is based on the following documents:

FDIS	Report on voting
20/1782A/FDIS	20/1794/RVD

Full information on the voting for the approval of this International Standard can be found in the report on voting indicated in the above table.

This document has been drafted in accordance with the ISO/IEC Directives, Part 2.

It has the status of a group safety publication in accordance with IEC Guide 104.

The committee has decided that the contents of this publication will remain unchanged until the maintenance result date indicated on the IEC web site under "<http://webstore.iec.ch>" in the data related to the specific publication. At this date, the publication will be

- reconfirmed,
- withdrawn,
- replaced by a revised edition, or
- amended.

A bilingual version of this publication may be issued at a later date.

INTRODUCTION

IEC 60331 consists of the following parts under the general title: *Tests for electric cables under fire conditions – Circuit integrity*:

Part 1: *Test method for fire with shock at a temperature of at least 830 °C for cables of rated voltage up to and including 0,6/1,0 kV and with an overall diameter exceeding 20 mm*

Part 2: *Test method for fire with shock at a temperature of at least 830 °C for cables of rated voltage up to and including 0,6/1,0 kV and with an overall diameter not exceeding 20 mm*

Part 3: *Test method for fire with shock at a temperature of at least 830 °C for cables of rated voltage up to and including 0,6/1,0 kV tested in a metal enclosure*

Part 11: *Apparatus – Fire alone at a flame temperature of at least 750 °C*

Part 21: *Procedures and requirements – Cables of rated voltage up to and including 0,6/1,0 kV*

Part 23: *Procedures and requirements – Electric data cables*

Part 25: *Procedures and requirements – Optical fibre cables*

NOTE 1 Parts 21, 23 and 25 relate to fire-only conditions at a flame temperature of at least 750 °C.

NOTE 2 Parts 11, 21, 23 and 25 are no longer subject to maintenance. IEC 60331 Parts 1 and 2 are the recommended test procedures

Since its first edition (1970), IEC 60331 has been extended and has introduced a range of test apparatus in order that a test may be carried out on large and small power, control, data and optical fibre cables.

IEC 60331-3 introduces apparatus and a procedure to allow cables to be tested in a metal enclosure under conditions of mechanical shock as well as fire at temperature of at least 830 °C.

TESTS FOR ELECTRIC CABLES UNDER FIRE CONDITIONS – CIRCUIT INTEGRITY –

Part 3: Test method for fire with shock at a temperature of at least 830 °C for cables of rated voltage up to and including 0,6/1,0 kV tested in a metal enclosure

1 Scope

This part of IEC 60331 specifies the test method for cables which are required to maintain circuit integrity when tested in a metal enclosure and when subject to fire and mechanical shock under specified conditions.

This document is applicable to cables of rated voltage not exceeding 600 V/1 000 V, including those of rated voltage below 80 V, metallic data and telecom cables and optical fibre cables.

It is intended for use when testing cables not greater than 20 mm overall diameter.

This document includes details for the specific point of failure, continuity checking arrangement, test sample, test procedure and test report relevant to electric power and control cables with rated voltage up to and including 600 V/1 000 V. Details for the specific point of failure, continuity checking arrangement, test sample, test procedure and test report relevant to metallic data and telecom cables and optical fibre cables are not given by IEC 60331-3.

Although the scope is restricted to cables with rated voltage up to and including 0,6/1,0 kV, the procedure can be used, with the agreement of the manufacturer and the purchaser, for cables with rated voltage up to and including 1,8/3 (3,3) kV, provided that suitable fuses are used.

It is not assumed that cables successfully assessed by this method, will also pass requirements for either IEC 60331-1 or IEC 60331-2. Testing to either of these two standards is to be carried out separately. Such additional performance can be recognised by the marking in accordance with IEC 60331-1:2018 Clause 11 or IEC 60331-2:2018 Clause 11.

Annex A provides the method of verification of the burner and control system used for the test.

CAUTION – The test given in this standard may involve the use of dangerous voltages and temperatures. Suitable precautions should be taken against the risk of shock, burning, fire and explosion that may be involved, and against any noxious fumes that may be produced.

2 Normative references

The following documents are referred to in the text in such a way that some or all of their content constitutes requirements of this document. For dated references, only the edition cited applies. For undated references, the latest edition of the referenced document (including any amendments) applies.

IEC 60269-3, *Low-voltage fuses – Part 3: Supplementary requirements for fuses for use by unskilled persons (fuses mainly for household and similar applications) – Examples of standardized systems of fuses A to F*

IEC 60331-1:2018, *Test for electric cables under fire conditions – Circuit integrity – Part 1: Test for circuit integrity under conditions of fire with shock at a temperature of at least 830 °C for cables of rated voltage up to and including 0,6/1,0kV and with an overall diameter exceeding 20 mm*

IEC 60331-2:2018, *Test for electric cables under fire conditions – Circuit integrity – Part 2: Test for circuit integrity under conditions of fire with shock at a temperature of at least 830 °C for cables of rated voltage up to and including 0,6/1,0kV and with an overall diameter not exceeding 20 mm*

IEC 60584-1, *Thermocouples – Part 1: EMF specifications and tolerances*

3 Terms and definitions

For the purposes of this document, the following terms and definitions apply.

ISO and IEC maintain terminological databases for use in standardization at the following addresses:

- IEC Electropedia: available at <http://www.electropedia.org/>
- ISO Online browsing platform: available at <http://www.iso.org/obp>

3.1

circuit integrity

ability of an electric cable to continue to operate in a designated manner whilst subjected to a specified flame source for a specified period of time under specified conditions

3.2

draught-free environment

space in which the results of tests are not significantly affected by the local air speed

4 Test environment

The test shall be carried out in a draught-free environment within a suitable chamber, of minimum volume 20 m³, with facilities for disposing of any noxious gases resulting from the burning. Sufficient ventilation shall be available to sustain the flame for the duration of the test. Air inlets and the exhaust chimney should be located in such a way that the burner flame remains stable during the verification procedure and test. If necessary, the burner shall be shielded from any draughts by the use of draught shields. Windows may be installed in the walls of the chamber in order to observe the behaviour of the cable during the test. Fume exhaust should be achieved by means of natural draught through a chimney located at least 1 m from the burner. A damper may be used for adjustment of ventilation conditions.

NOTE Experience has shown a chamber similar to the “3 m cube” specified in IEC 61034-1 to be suitable.

The chamber and test apparatus shall be at a temperature of between 10 °C and 40 °C at the start of each test.

The same ventilation and shielding conditions shall be used in the chamber during both the verification and cable test procedures.

5 Test apparatus

5.1 Test equipment

The test equipment shall consist of the following:

- a) a metal enclosure, through which the test specimen(s) are drawn, constructed from a straight stainless steel tube of circular cross-section as described in 5.2;
- b) a test ladder, onto which the metal enclosure is mounted, comprising a steel framework fastened to a rigid support as described in 5.3;
- c) a source of heat comprising a horizontally mounted ribbon burner as described in 5.4;
- d) a shock-producing device as described in 5.5;
- e) a test wall equipped with thermocouples for verification of the source of heat as described in Annex A;
- f) a continuity checking arrangement as described in 5.7;
- g) fuses as described in 5.8.

A general arrangement of the test equipment is shown in Figure 1, Figure 2, Figure 3 and Figure 4.

5.2 Metal enclosure

5.2.1 Material and dimensions

The enclosure shall comprise a straight stainless steel tube of circular cross-section, manufactured free from surface irregularities. The metal enclosure shall be $(1\ 300 \pm 50)$ mm long and shall conform to dimensions as detailed in Table 1.

NOTE 1 Metal conduit as defined in IEC 60614-2-1:1982 has been found to be suitable for the enclosure.

NOTE 2 AISI grades 304 and 316 have been found to be suitable materials for the enclosure.

Table 1 – Enclosure dimensions

Size mm	Wall thickness mm
20	$1,6 \pm 0,15$
40	$1,6 \pm 0,15$

5.2.2 Metal enclosure selection

The particular metal enclosure shall be selected using the criteria given in 6.2.

5.3 Test ladder and mounting

The test ladder shall consist of a steel framework as shown in Figure 1. The vertical elements of the ladder shall be fixed at (400 ± 20) mm spacing. The test ladder shall be $(1\ 200 \pm 100)$ mm long and (600 ± 50) mm high, and the total mass of the test ladder shall be (18 ± 1) kg. Ballast, if required, shall be placed on the steel supports.

NOTE 1 Angle iron approximately 45 mm wide and 6 mm thick, with suitable slots cut to allow for fixing of the bolts or saddles, has been found to be a suitable material for construction of the ladder.

The metal enclosure shall be rigidly mounted centrally on the test ladder, as shown in Figure 2. Suitably sized saddles or U-bolts are recommended for fixing on the vertical elements.

NOTE 2 It is important that the fixings are tight enough to prevent vertical movement of the metal enclosure whilst allowing longitudinal expansion of the metal enclosure.

Each horizontal element shall have a mounting hole not more than 200 mm from each end, the exact position and diameter being determined by the particular supporting bush and supporting framework used. The test ladder shall be fastened to a rigid support by four bonded rubber bushes of hardness 50–60 Shore A fitted between the horizontal steel

elements of the ladder and the support framework, as shown in Figure 1 and Figure 3, so as to allow movement under impact.

NOTE 3 A typical rubber bush, which has been found to be suitable, is shown in Figure 5.

Dimensions in millimetres

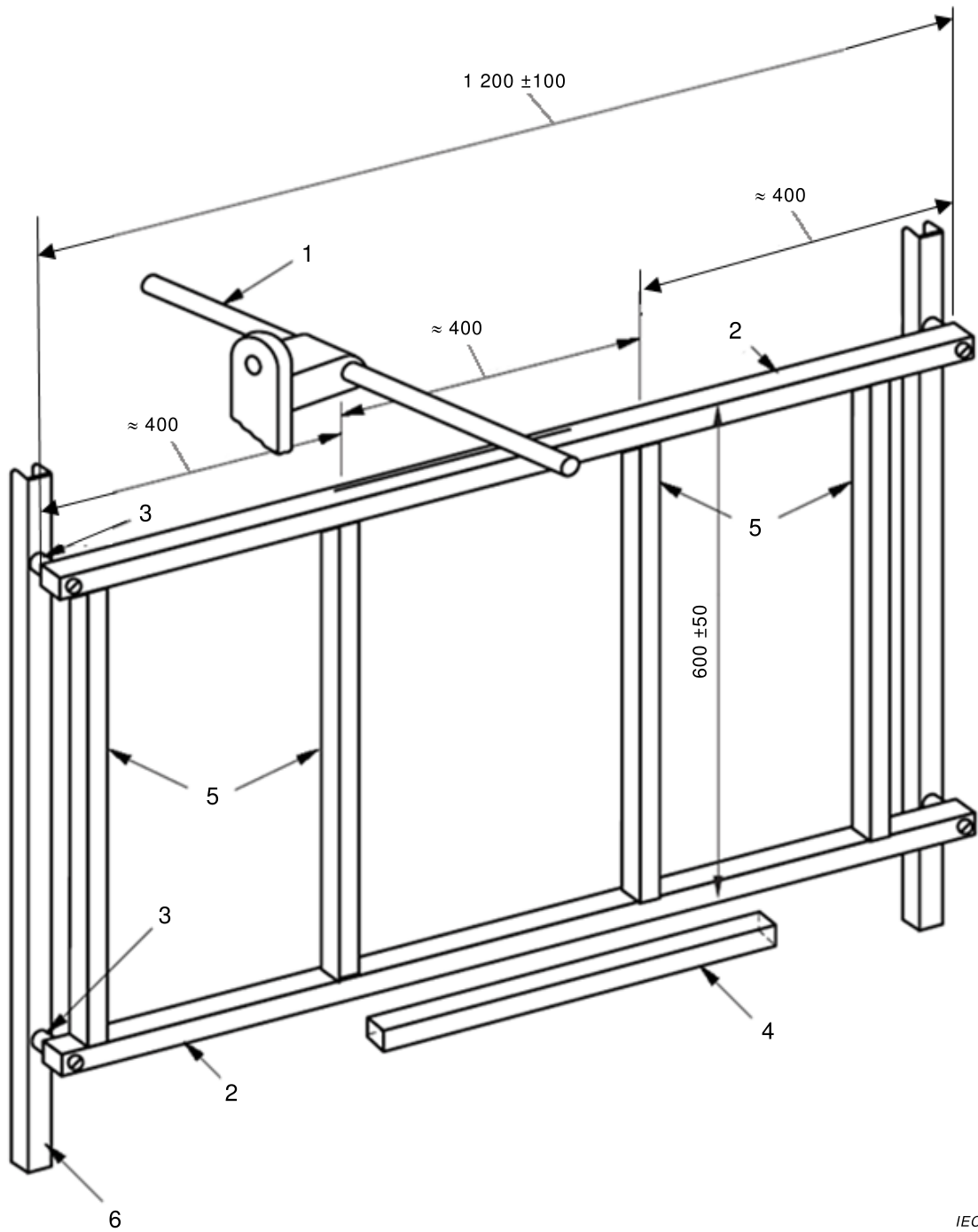

IEC

Key

- | | | | |
|---|------------------------|---|------------------------|
| 1 | shock-producing device | 4 | ribbon gas burner |
| 2 | steel ladder | 5 | fixed vertical element |
| 3 | rubber bush | 6 | ladder support |

Figure 1 – Schematic diagram of test configuration

*Dimensions in millimetres
(dimensions are approximate)*

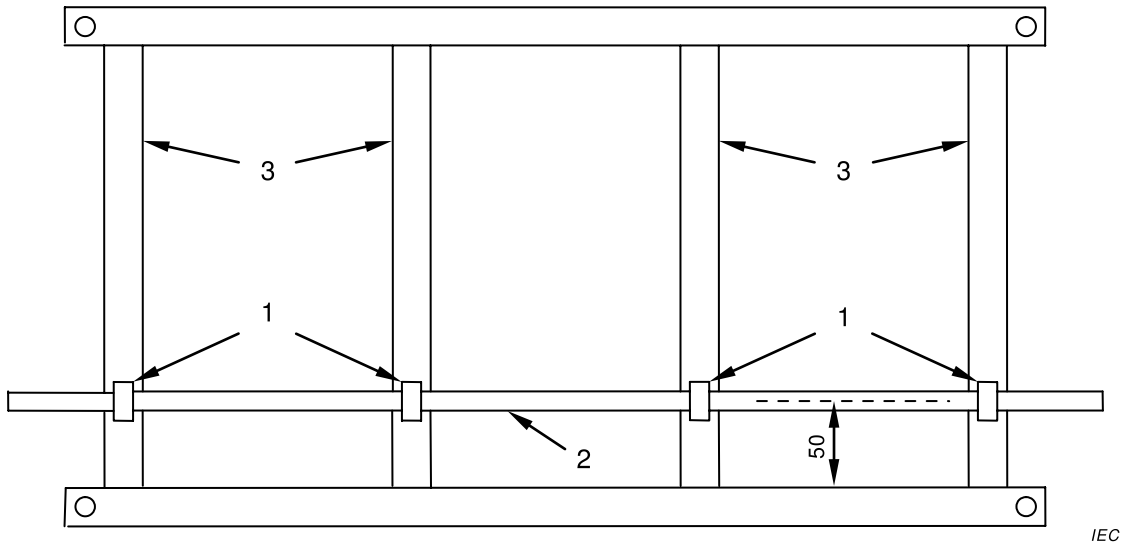

IEC

Key

- 1 U-bolt
- 2 metal enclosure
- 3 fixed vertical elements

Figure 2 – Recommended method of mounting the metal enclosure to the test ladder

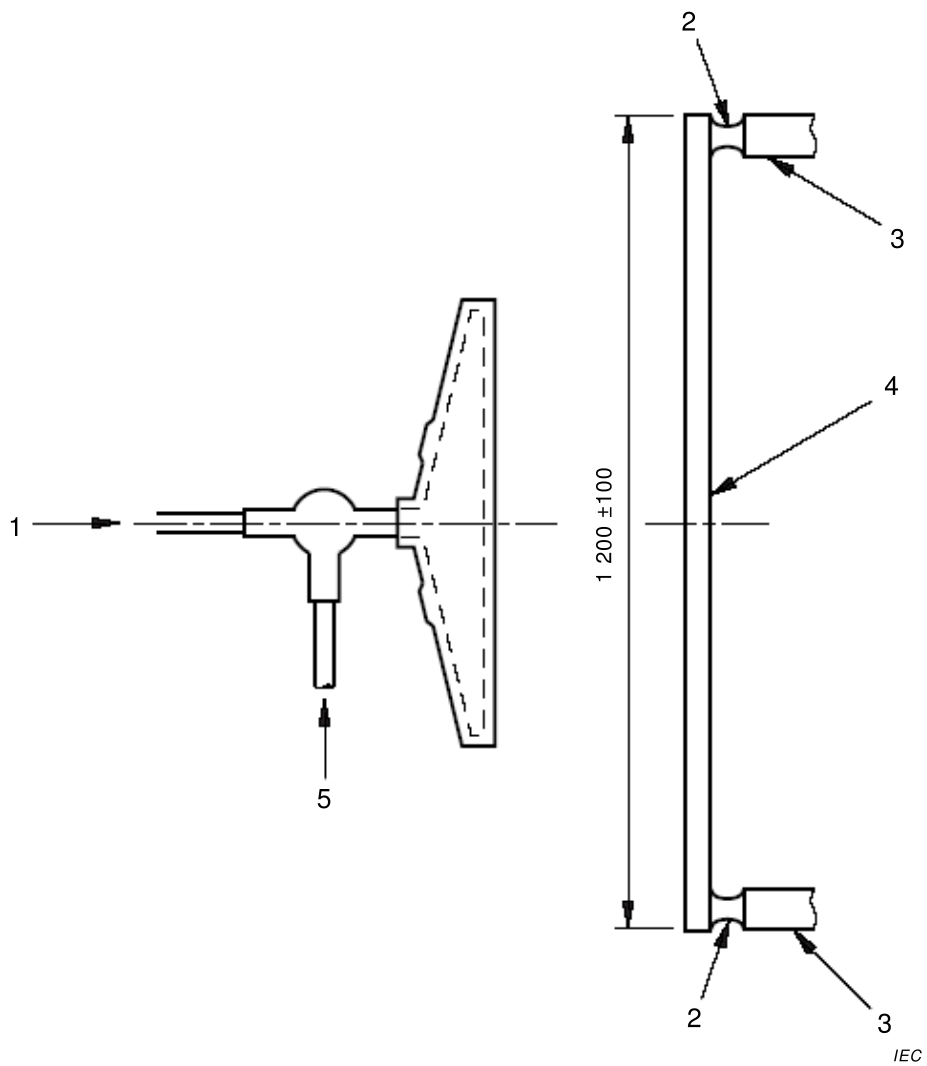
Dimensions in millimetres**Key**

- | | | | |
|---|-------------------|---|------------------------------|
| 1 | entry for air | 4 | horizontal steel test ladder |
| 2 | rubber bush | 5 | entry for propane gas |
| 3 | support framework | | |

Figure 3 – Plan view of fire test equipment

Dimensions in millimetres

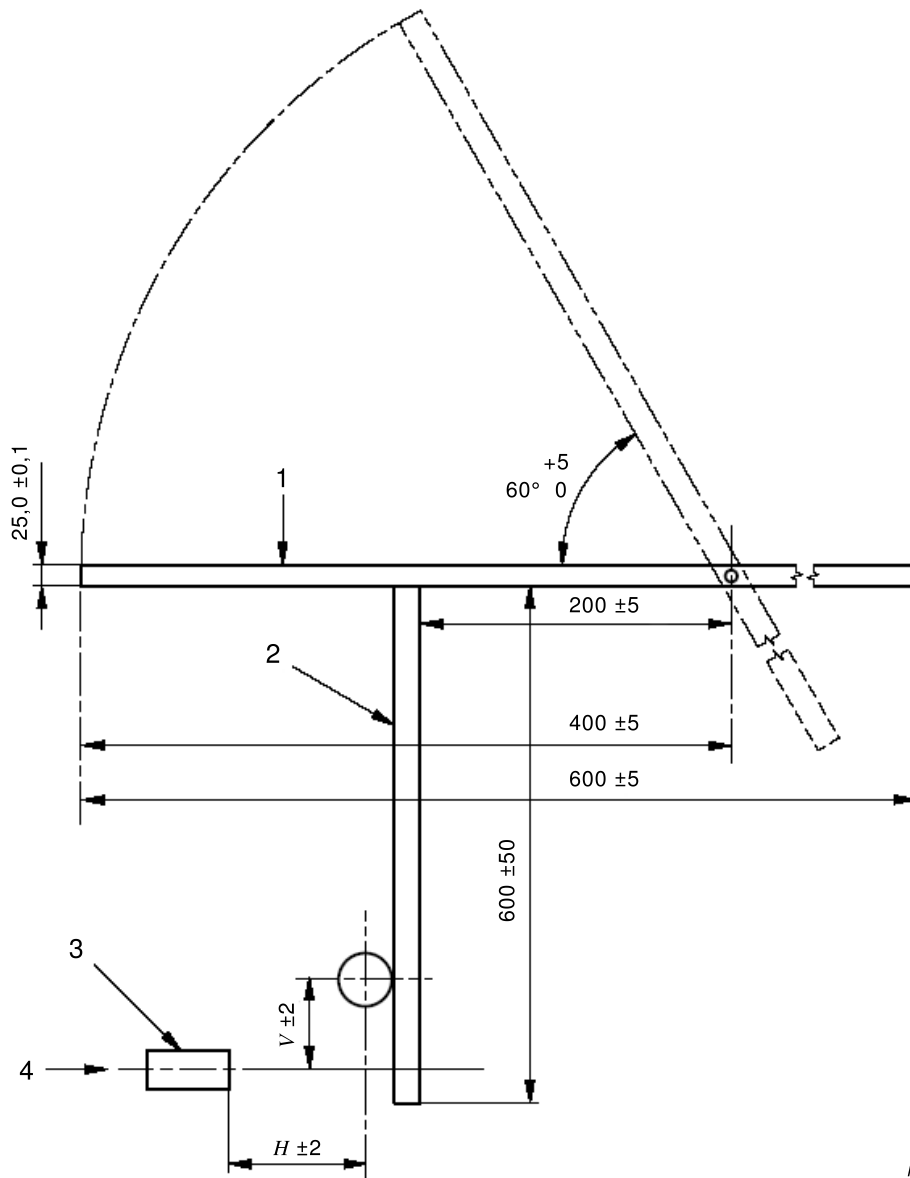

IEC

Key

- | | | | |
|---|----------------------------|----------|-----------------------------------------------------------------------------|
| 1 | shock-producing device | <i>H</i> | horizontal distance of metal enclosure centre line from burner face |
| 2 | steel test ladder | <i>V</i> | vertical distance of metal enclosure centre line from centre line of burner |
| 3 | gas burner | | |
| 4 | centre line of burner face | | |

Figure 4 – End elevation of fire test equipment
(not to scale)

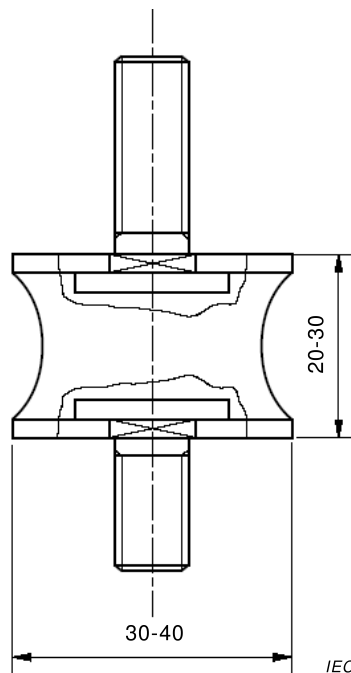

Figure 5 – Typical rubber bush for supporting the test ladder

5.4 Source of heat

5.4.1 Burner

The source of heat shall be a ribbon type propane gas burner with a nominal burner face length of 500 mm (outer distance between outer holes) with a venturi mixer. The nominal burner face width shall be 10 mm. The face of the burner shall have three staggered rows of drilled holes, nominally 1,32 mm in diameter and drilled at centres 3,2 mm from one another, as shown in Figure 6.

A centre-feed burner is recommended.

A row of small holes milled on each side of the burner plate, to serve as pilot holes for keeping the flame burning, is permitted.

Guidance on the choice of a recommended burner system is given in Annex B.

*Dimensions in millimetres
(Dimensions are approximate)*

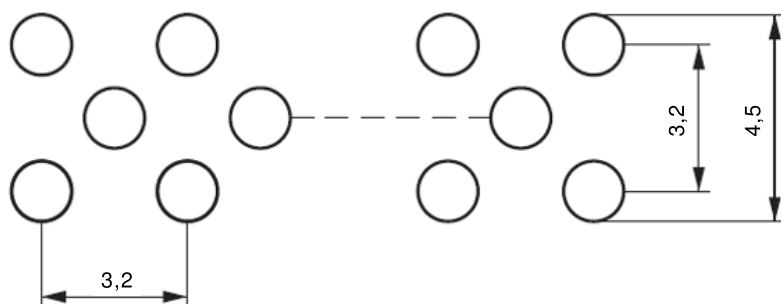

IEC

NOTE Round holes, 1,32 mm in diameter, on centres 3,2 mm from one another, staggered in three rows and centred on the face of the burner. Nominal burner face length 500 mm.

Figure 6 – Burner face

5.4.2 Flow meters and flow rates

Mass flow meters/controllers shall be used as the means of controlling accurately the input flow rates of fuel and air to the burner.

For the purposes of this test, the air shall have a dew point not higher than 0 °C.

The mass flow rates used for the test shall be as follows:

Propane: (320 ± 13) mg/s

NOTE 1 This is approximately equivalent to a volume flow rate of (10,0 ± 0,4) litres/min at reference conditions (1 bar and 20 °C).

The purity of the propane is not defined. Industrial grades that contain impurities are allowed provided that the calibration requirements are achieved.

Air: (3 270 ± 163) mg/s

NOTE 2 This is approximately equivalent to a volume flow rate of (160 ± 8) litres/min at reference conditions (1 bar and 20 °C).

A schematic diagram of an example of a burner control system is given in Figure 7.

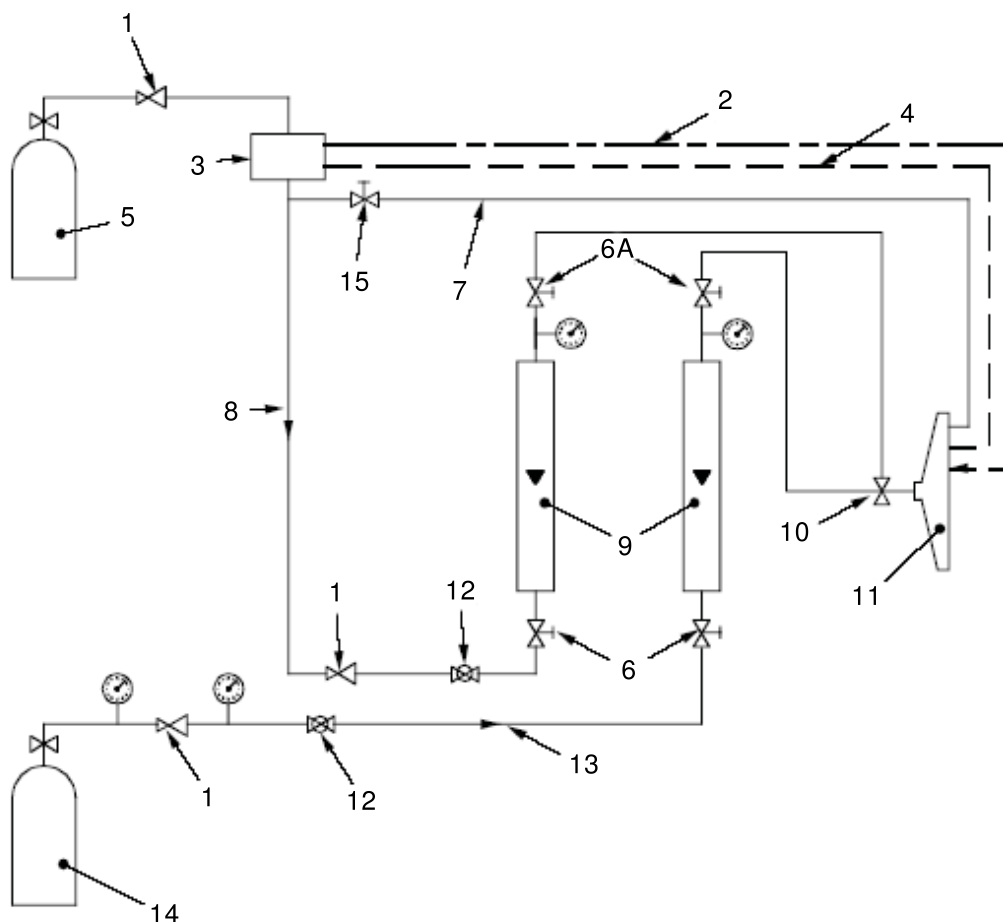

IEC

Key

1	regulator	9	mass flow meters
2	piezoelectric igniter	10	venturi mixer
3	flame failure device	11	burner
4	control thermocouples	12	ball valve
5	propane cylinder	13	air flow
6	screw valve (6A = alternative position)	14	compressed air cylinder
7	pilot feed	15	screw valve on pilot feed
8	gas flow		

Figure 7 – Schematic diagram of an example of a burner control system

5.4.3 Verification

The burner and control system shall be subject to verification following the procedure given in Annex A.

5.5 Shock-producing device

The shock-producing device shall consist of a mild steel round bar ($25,0 \pm 0,1$) mm in diameter and (600 ± 5) mm long. The bar shall be freely pivoted about an axis parallel to the test ladder, which shall be in the same horizontal plane as, and (200 ± 5) mm away from, the upper edge of the ladder. The axis shall divide the bar into two unequal lengths, the longer length being (400 ± 5) mm which shall impact the ladder. The bar shall drop under its own

weight from an angle of $(60^{+5}_0)^\circ$ to the horizontal to strike the upper edge of the ladder at its midpoint as shown in Figure 1 and Figure 4.

5.6 Positioning of source of heat

The burner face shall be positioned in the test chamber so that it is at least 200 mm above the floor of the chamber, or any solid mounting block, and at least 500 mm from any chamber wall.

By reference to the centre point of the metal enclosure, the burner shall be positioned centrally at a horizontal distance of $(H \pm 2)$ mm from the burner face to the centre of the metal enclosure and at a vertical distance of $(V \pm 2)$ mm from the burner centre line to the centre of the metal enclosure, as shown in Figure 4.

The exact burner location to be used during cable testing shall be determined using the verification procedure given in Annex A, where the values of H and V to be used shall be determined.

The burner should be rigidly fixed to the framework during testing so as to prevent movement relative to the metal enclosure.

5.7 Continuity checking arrangements for electric power and control cables with rated voltage up to and including 600 V/1 000 V

During the test, a current for continuity checking shall be passed through all conductors of the test specimen(s). This shall be provided by a three-phase star connected or single-phase transformer(s) of sufficient capacity to maintain the test voltage up to the maximum leakage current allowable.

NOTE 1 Note the fuse characteristics when determining the power rating of the transformer.

This current shall be achieved by connecting, at the other end of the specimen, a suitable load and an indicating device (e.g. lamp) to each conductor, or group of conductors.

NOTE 2 A current of 0,25 A at the test voltage, through each conductor or group of conductors, has been found to be suitable.

5.8 Fuses

Fuses used in the test procedure in Clause 7 shall comply with IEC 60269-3 Fuse System A-D Type DII, 2A. Alternatively, a circuit-breaker with equivalent characteristics may be used.

Where a circuit-breaker is used, its equivalent characteristics shall be demonstrated by reference to the characteristic curve shown in IEC 60269-3.

The test method using fuses shall be the reference method in the case of dispute.

6 Test specimen (electric power and control cables with rated voltage up to and including 600 V/1 000 V)

6.1 Test specimen preparation

A cable sample at least 15,3 m long for single core, or 5,1 m long for multi-core, shall be available from the cable length for test. The test specimen to be tested shall consist of either a single piece of multi-core cable or three pieces of single core cable not less than 1 700 mm long with approximately 100 mm of sheath or outer covering removed at each end.

At each end of the test specimen, each conductor shall be suitably prepared for electrical connections, and after being drawn into the appropriate metal enclosure, the exposed conductors shall be spread apart to avoid contact with each other.

6.2 Test specimen mounting

The test specimen(s) shall be drawn into the appropriate metal enclosure and shall rest on the wall of the enclosure. The enclosure to be used for a particular cable diameter shall be selected in accordance with Table 2 for multicore sheathed cable (including multipair and multi-triple cables), or Table 3 for single core sheathed or unsheathed cable.

Table 2 – Multicore sheathed cable

Cable diameter mm	Metal enclosure size mm
Up to 11,0	20
11,0 to 23,0	40

Table 3 – Single core unsheathed or sheathed cable

Cable diameter mm	Metal enclosure size mm
Up to 6,2	20
6,2 to 13,5	40

The test specimen(s) shall be positioned in the metal enclosure such that it extends outside the enclosure by greater than 100 mm at each end.

7 Test procedure (electric power and control cables with rated voltage up to and including 600 V/1 000 V)

7.1 Test equipment and arrangement

The test procedure defined in this clause shall be carried out using the apparatus detailed in Clause 5.

Draw the test specimen(s) into the metal enclosure and adjust the burner to the correct position relative to the enclosure in accordance with 5.6.

7.2 Electrical connections

At the transformer end of the test specimen(s), earth the neutral conductor, if present, and any protective conductors. Any metal screens, drain wire or metal layer shall be interconnected and earthed. Connect the transformer(s) to the conductors, excluding any conductor which is specifically identified as intended for use as a neutral or a protective conductor, as shown in the circuit diagram in Figure 8. Where a metal sheath, armour or screen acts as a neutral or protective conductor, it shall be connected, as shown in the circuit diagram in Figure 8, as for a neutral or protective conductor. The metal enclosure shall be earthed.

For single-, twin- or three-phase conductor cables, connect each phase conductor to a separate phase of the transformer(s) output with a 2 A fuse or circuit-breaker with equivalent characteristics in each phase. When the test specimen comprises 3 single-core cables, each single-core test piece shall be considered as a phase conductor.

For multicore cables that have four or more conductors (excluding any neutral or protective conductors), the conductors shall be divided into three roughly equal groups, ensuring that adjacent conductors are, as far as possible, in different groups.

For multipair cables, the conductors shall be divided into two equal groups, ensuring that the a-core of each pair is connected to one phase and the b-core of each pair is connected to another phase (L1 and L2 in Figure 8). Quads shall be treated as two pairs.

For multi-triple cables, the conductors shall be divided into three equal groups, ensuring that the a-core of each triple is connected to one phase, the b-core of each triple to another phase and the c-core of each triple to the third phase of the transformer (L1, L2 and L3 in Figure 8).

Connect the conductors of each group in series and connect each group to a separate phase of the transformer output with a 2 A fuse or circuit-breaker with equivalent characteristics in each phase.

The above test procedure connects the neutral conductor to earth. This may not be appropriate if the cable is designed for use on a system where neutral is not earthed. If required by the cable standard it is permissible for the neutral conductor to be tested as if it were a phase conductor. Where a metal sheath, armour or screen acts as a neutral conductor, it shall always be connected to earth. Any such variations in methodology should be included in the test report.

For cable constructions not specifically identified above, the test voltage should be applied, as far as is practicable, to ensure that adjacent conductors are connected to different phases.

In certain cases, for example when testing a control cable using a three-phase transformer, it may not be possible to apply a test voltage between conductors and from conductor to earth equal to the rated voltage simultaneously. In such cases, either the test voltage between conductors, or the test voltage from conductor to earth shall be equal to the rated voltage, such that both the test voltage between conductors and the test voltage from conductor to earth is equal to or higher than the rated voltage.

At the end of the sample remote from the transformer:

- connect each phase conductor, or group of conductors, to one terminal of the load and indicating device (as described in 5.7), the other terminal being earthed;
- connect the neutral conductor and any protective conductor to one terminal of the load and indicating device (as described in 5.7), the other terminal being connected to L1 (or L2 or L3) at the transformer end (see Figure 8).

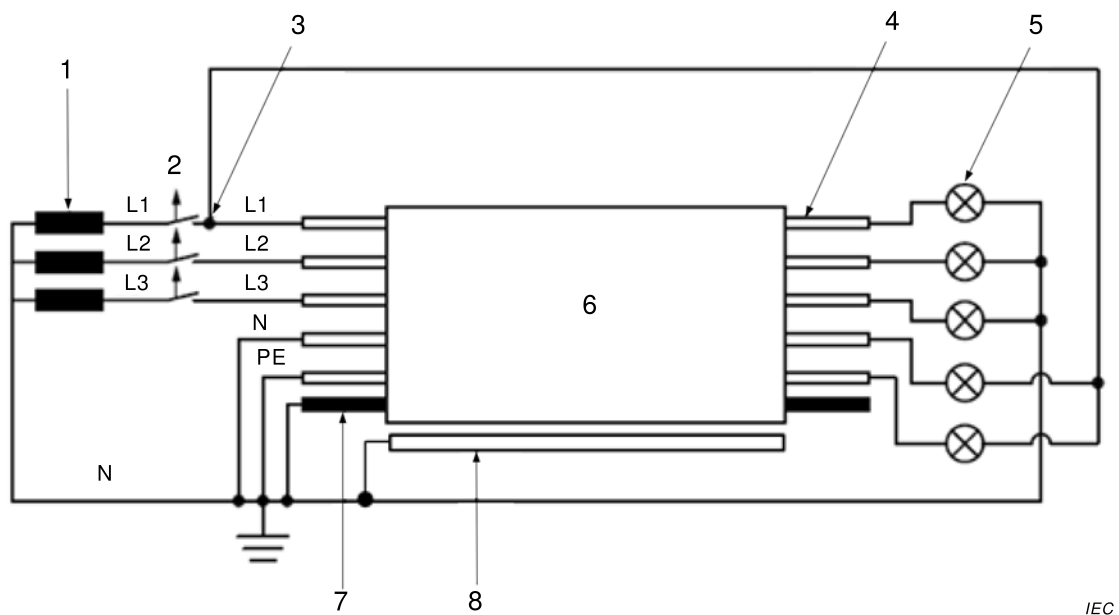

IEC

Key

L1, L2, L3	phase conductor (L2, L3 if present)
N	neutral conductor (if present)
PE	protective conductor (if present)

1	transformer	5	load and indicating device
2	fuse, 2 A	6	test specimen
3	L1 or L2 or L3	7	metal screen (if present)
4	test conductor or group	8	metal enclosure

Figure 8 – Basic circuit diagram**7.3 Flame and shock application**

Ignite the burner and adjust the propane and air flow rates to those obtained during the verification procedure (see Annex A).

Immediately after igniting the burner, activate the shock-producing device and start the test duration timer. The shock-producing device shall impact the ladder after $5 \text{ min} \pm 10 \text{ s}$ from activation and subsequently at $5 \text{ min} \pm 10 \text{ s}$ intervals. After each impact, the impacting bar shall be raised from the test ladder no more than 20 s after the impact.

7.4 Electrification

Immediately after starting the test duration timer, switch on the electricity supply and adjust the voltage to the rated voltage of the sample (subject to a minimum voltage of 100 V AC), i.e. the test voltage between conductors shall equal the rated voltage between conductors, and the test voltage from conductor to earth shall equal the rated voltage from conductor to earth.

The test shall continue for the flame application time given in 8.1, after which the flame shall be extinguished.

8 Performance requirements (electric power and control cables with rated voltage up to and including 600 V/1 000 V)

8.1 Flame application time

The flame application time shall be as specified in the relevant cable standard. In the absence of such a standard, a flame and impact application time of 30 min, 60 min, 90 min or 120 min shall be chosen.

8.2 Acceptance criteria

With reference to the test procedure given in Clause 7, the cable possesses the characteristics for providing circuit integrity so long as during the course of the test

- the voltage is maintained, i.e. no fuse fails or circuit-breaker is interrupted,
- a conductor does not rupture, i.e. the lamp is not extinguished.

Failure by either one of the criteria listed shall be sufficient to show a failure for that cable.

9 Retest procedure

In the event of a failure, as judged by the requirements of the relevant standard, two further test specimens, taken from the same cable sample, shall be tested. If both comply, the test shall be deemed successful.

10 Test report (electric power and control cables with rated voltage up to and including 600 V/1 000 V)

The test report shall include the following information:

- a) the number of this document;
- b) a full description of the cable tested;
- c) the manufacturer of the cable tested;
- d) the number of test pieces in the test specimen;
- e) the dimensions of the metal enclosure;
- f) the test voltage;
- g) any option used in the test procedure (i.e. failure detection method);
- h) the method used for temperature monitoring during the verification procedure (see Annex A);
- i) the point of failure mechanism (i.e. voltage not maintained or conductor rupture);
- j) the actual performance requirement applied (by reference to Clause 8 or to the relevant cable standard);
- k) the flame application time;
- l) any variation from the specified test procedure;
- m) the chamber volume and temperature at the start of the test.

Annex A (normative)

Verification procedure for the source of heat

A.1 Measuring equipment

The flame temperature shall be measured using two 1,5 mm mineral insulated, stainless steel sheathed thermocouples type K conforming to IEC 60584-1, mounted on the test wall as shown in Figure A.1. The thermocouple tips shall be $(20,0 \pm 1,0)$ mm in front of the test wall. The horizontal line of the thermocouples shall be (100 ± 10) mm above the bottom of the wall. The wall shall consist of a board of heat-resisting non-combustible and non-metallic material, (900 ± 100) mm long, (300 ± 50) mm high and (10 ± 2) mm thick.

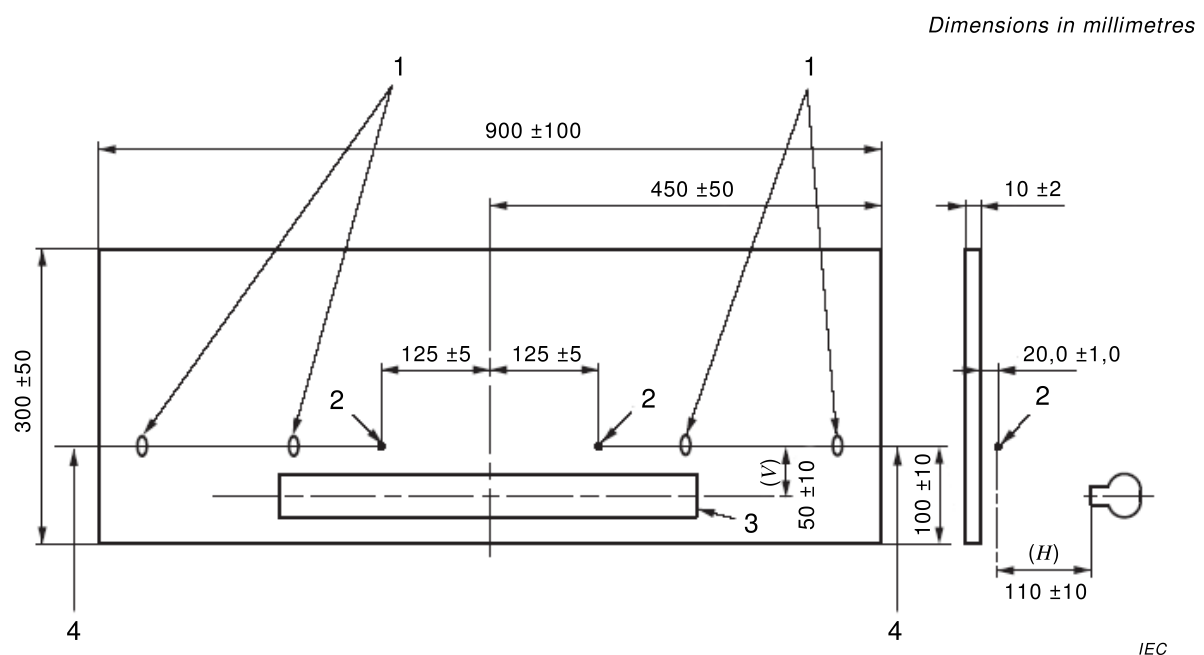

Key

- | | |
|----------|------------------------------------------------------------------|
| 1 | thermocouple supports |
| 2 | thermocouple tip |
| 3 | burner |
| 4 | 1,5 mm type K sheathed thermocouples |
| 5 | test wall |
| <i>H</i> | horizontal distance of thermocouple tip from burner face |
| <i>V</i> | vertical distance of thermocouple tip from centre line of burner |

Figure A.1 – Temperature measuring arrangement

A.2 Procedure

Position the burner 100 mm to 120 mm horizontally from the thermocouple (*H*) and 40 mm to 60 mm vertically below the centre line of the thermocouples (*V*) as shown in Figure A.1.

Ignite the burner and adjust the gas and air supplies to those given in 5.4.2.

Monitor the temperature as recorded by the thermocouples over a period of 10 min to ensure conditions are stable.

A.3 Evaluation

The verification procedure shall be considered satisfactory if

- a) the arithmetic mean of the averaged readings for each of the two thermocouples over the 10 min falls within the requirement of (830^{+40}_0) °C, and
- b) the difference of the averaged readings for each of the two thermocouples over the 10 min period does not exceed 40 °C.

At least one measurement shall be made every 30 s in order to obtain the average.

The actual method of obtaining the average thermocouple reading over the period is not specified, but it is recommended that a recorder with averaging facilities is used in order to damp the variability caused by point measurement.

If the verification is not successful, the flow rates shall be altered within the tolerances given in 5.4.2 and a further verification carried out.

A.4 Further verification

If the verification of Clause A.3 is not successful, the distances (H and V) between burner and thermocouples shall be altered (within the tolerance given in Clause A.2) and a further verification carried out.

If no successful verification can be achieved within the tolerances given, then the burner system shall be considered as incapable of providing the source of heat required by this standard.

A.5 Verification report

The positions established for successful verification (H and V) and flow rates used shall be recorded.

Annex B
(informative)

**Guidance on the choice of recommended test apparatus
(burner and venturi)¹**

A commercially available burner face meeting the recommendations of this standard is the AGF burner insert 11-55, and a suitable 500 mm burner, including the specified burner face, is the AGF, reference 1857B.

A recommended venturi mixer is the AGF 14-18.

The recommended burner and venturi are available from:

AGF Burner, Inc.
www.agfburner.com
1955 Swarthmore Ave
Lakewood, NJ 08703-8060

¹ This information is given for the convenience of users of this International Standard and does not constitute an endorsement by IEC of the product named. Equivalent products may be used if they can be shown to lead to the same results.

Bibliography

IEC 61034-1, *Measurement of smoke density of cables burning under defined conditions – Part 1: Test apparatus*

IEC 60614-2-1:1982, *Specification for conduits for electrical installations – Part 1: Particular specifications for conduits – Section one: Metal conduits*

INTERNATIONAL
ELECTROTECHNICAL
COMMISSION

3, rue de Varembé
PO Box 131
CH-1211 Geneva 20
Switzerland

Tel: + 41 22 919 02 11
Fax: + 41 22 919 03 00
info@iec.ch
www.iec.ch